

Transformer Module

IT-E760 Series User Manual



Model: IT-E761A/IT-E762A/IT-E763A/IT-E764A/IT-E765A/IT-E766A
Version: V1.0 / 2, 2019

Notices

© Itech Electronic, Co., Ltd. 2019

No part of this manual may be reproduced in any form or by any means (including electronic storage and retrieval or translation into a foreign language) without prior permission and written consent from Itech Electronic, Co., Ltd. as governed by international copyright laws.

Manual Part Number



402225

Trademarks

Pentium is U.S. registered trademarks of Intel Corporation.

Microsoft, Visual Studio, Windows and MS Windows are registered trademarks of Microsoft Corporation in the United States and/or other countries and regions.

Warranty

The materials contained in this document are provided “as is”, and is subject to change, without prior notice, in future editions. Further, to the maximum extent permitted by applicable laws, ITECH disclaims all warranties, either express or implied, with regard to this manual and any information contained herein, including but not limited to the implied warranties of merchantability and fitness for a particular purpose. ITECH shall not be held liable for errors or for incidental or indirect damages in connection with the furnishing, use or application of this document or of any information contained herein. Should ITECH and the user enter into a separate written agreement with warranty terms covering the materials in this document that conflict with these terms, the warranty terms in the separate agreement shall prevail.

Technology Licenses

The hardware and/or software described herein are furnished under a license and may be used or copied only in accordance with the terms of such license.

Restricted Rights Legend

Restricted permissions of the U.S. government. Permissions for software and technical data which are authorized to the U.S. Government only include those for custom provision to end users. ITECH follows FAR 12.211 (technical data), 12.212 (computer software). DFARS 252.227-7015 (technical data—commercial products) for national defense and DFARS 227.7202-3 (permissions for commercial computer software or computer software documents) while providing the customized business licenses of software and technical data.

Safety Notices

CAUTION

A CAUTION sign denotes a hazard. It calls attention to an operating procedure or practice that, if not correctly performed or adhered to, could result in damage to the product or loss of important data. Do not proceed beyond a CAUTION sign until the indicated conditions are fully understood and met.

WARNING

A WARNING sign denotes a hazard. It calls attention to an operating procedure or practice that, if not correctly performed or adhered to, could result in personal injury or death. Do not proceed beyond a WARNING sign until the indicated conditions are fully understood and met.



Note

A NOTE sign denotes important hint. It calls attention to tips or supplementary information that is essential for users to refer to.

Quality Certification and Assurance

We certify that series instrument meets all the published specifications at time of shipment from the factory.

Warranty

ITECH warrants that the product will be free from defects in material and workmanship under normal use for a period of one (1) year from the date of delivery (except those described in the Limitation of Warranty below).

For warranty service or repair, the product must be returned to a service center designated by ITECH.















- The product returned to ITECH for warranty service must be shipped PRE-PAID. And ITECH will pay for return of the product to customer.
- If the product is returned to ITECH for warranty service from overseas, all the freights, duties and other taxes shall be on the account of customer.

Limitation of Warranty

This Warranty will be rendered invalid in case of the following:

- Damage caused by circuit installed by customer or using customer own products or accessories;
- Modified or repaired by customer without authorization;
- Damage caused by circuit installed by customer or not operating our products under designated environment;
- The product model or serial number is altered, deleted, removed or made illegible by customer;
- Damaged as a result of accidents, including but not limited to lightning, moisture, fire, improper use or negligence.

Safety Symbols

	Direct current		ON (power)
	Alternating current		OFF (power)
	Both direct and alternating current		Power-on state
	Chassis (earth ground) symbol.		Power-off state
	Earth (ground) terminal		Reference terminal
	Caution		Positive terminal
	Warning (refer to this manual for specific Warning or Caution information)		Negative terminal
	A chassis terminal	-	-

Safety Precautions

The following safety precautions must be observed during all phases of operation of this instrument. Failure to comply with these precautions or specific warnings elsewhere in this manual will constitute a default under safety standards of design, manufacture and intended use of the instrument. ITECH assumes no liability for the customer's failure to comply with these precautions.

WARNING

- Do not use the instrument if it is damaged. Before operation, check the casing to see whether it cracks. Do not operate the instrument in the presence of inflammable gasses, vapors or dusts.
 - The instrument is provided with a power cord during delivery and should be connected to a socket with a protective earth terminal, a junction box or a three-phase distribution box. Before operation, be sure that the instrument is well grounded.
 - Please always use the provided cable to connect the instrument.
 - Check all marks on the instrument before connecting the instrument to power supply.
 - Ensure the voltage fluctuation of mains supply is less than 10% of the working voltage range in order to reduce risks of fire and electric shock.
 - Do not install alternative parts on the instrument or perform any unauthorized modification.
 - Do not use the instrument if the detachable cover is removed or loosen.
 - To prevent the possibility of accidental injuries, be sure to use the power adapter supplied by the manufacturer only.
 - We do not accept responsibility for any direct or indirect financial damage or loss of profit that might occur when using the instrument.
 - This instrument is used for industrial purposes, do not apply this product to IT power supply system.
 - Never use the instrument with a life-support system or any other equipment subject to safety requirements.
-

WARNING

- **SHOCK HAZARD Ground the Instrument.** This product is provided with a protective earth terminal. To minimize shock hazard, the instrument must be connected to the AC mains through a grounded power cable, with the ground wire firmly connected to an electrical ground (safety ground) at the power outlet or distribution box. Any interruption of the protective (grounding) conductor or disconnection of the protective earth terminal will cause a potential shock hazard that could result in injury or death.
- Before applying power, verify that all safety precautions are taken. All connections must be made with the instrument turned off, and must be performed by qualified personnel who are aware of the hazards involved. Improper actions can cause fatal injury as well as equipment damage.
- **SHOCK HAZARD, LETHAL VOLTAGES** This product can output the dangerous voltage that can cause personal injury, and the operator must always be protected from electric shock. Ensure that the output electrodes are either insulated or covered using the safety covers provided, so that no accidental contact with lethal voltages can occur.
- Never touch cables or connections immediately after turning off the instrument. Verify that there is no dangerous voltage on the electrodes or sense terminals before touching them.

CAUTION

- Failure to use the instrument as directed by the manufacturer may render its protective features void.
- Always clean the casing with a dry cloth. Do not clean the internals.
- Make sure the vent hole is always unblocked.

Environmental Conditions

The instrument is designed for indoor use and an area with low condensation. The table below shows the general environmental requirements for the instrument.



Environmental Conditions	Requirements
Operating temperature	0°C ~ 40°C
Operating humidity	20% ~ 80%(non-condensation)
Storage temperature	-10°C ~ 70 °C

Environmental Conditions	Requirements
Altitude	Operating up to 2,000 meters
Installation category	II
Pollution degree	Pollution degree 2

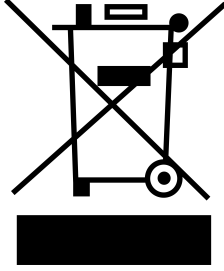

Note

In order to ensure the accuracy of measurement, it is recommended to operate the instrument half an hour after start-up.

Regulation Tag

	<p>The CE tag shows that the product complies with the provisions of all relevant European laws (if the year is shown, it indicates that the year when the design is approved).</p>
	<p>This instrument complies with the WEEE directive (2002/96/EC) tag requirements. This attached product tag shows that the electrical/electronic product cannot be discarded in household waste.</p>
	<p>This symbol indicates that no danger will happen or toxic substances will not leak or cause damage in normal use within the specified period. The service life of the product is 10 years. The product can be used safely within the environmental protection period; otherwise, the product should be put into the recycling system.</p>

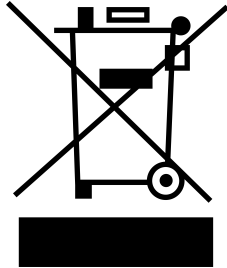
Waste Electrical and Electronic Equipment (WEEE) Directive



Waste electrical and electronic equipment (WEEE) directive, 2002/96/EC

The product complies with tag requirements of the WEEE directive (2002/96/EC). This tag indicates that the electronic equipment cannot be disposed of as ordinary household waste. Product Category

According to the equipment classification in Annex I of the WEEE directive, this instrument belongs to the "Monitoring" product.

If you want to return the unnecessary instrument, please contact the nearest sales office of ITECH.

Compliance Information

Complies with the essential requirements of the following applicable European Directives, and carries the CE marking accordingly:

- Electromagnetic Compatibility (EMC) Directive 2014/30/EU
- Low-Voltage Directive (Safety) 2014/35/EU

Conforms with the following product standards:

EMC Standard

IEC 61326-1:2012/ EN 61326-1:2013 ¹²³

Reference Standards

CISPR 11:2009+A1:2010/ EN 55011:2009+A1:2010 (Group 1, Class A)

IEC 61000-4-2:2008/ EN 61000-4-2:2009

IEC 61000-4-3:2006+A1:2007+A2:2010/ EN 61000-4-3:2006+A1:2008+A2:2010

IEC 61000-4-4:2004+A1:2010/ EN 61000-4-4:2004+A1:2010

IEC 61000-4-5:2005/ EN 61000-4-5:2006

IEC 61000-4-6:2008/ EN 61000-4-6:2009

IEC 61000-4-11:2004/ EN 61000-4-11:2004

1. The product is intended for use in non-residential/non-domestic environments. Use of the product in residential/domestic environments may cause electromagnetic interference.
2. Connection of the instrument to a test object may produce radiations beyond the specified limit.
3. Use high-performance shielded interface cable to ensure conformity with the EMC standards listed above.

Safety Standard

IEC 61010-1:2010/ EN 61010-1:2010

Content

Quality Certification and Assurance	I
Warranty	I
Limitation of Warranty	I
Safety Symbols	II
Safety Precautions	II
Environmental Conditions	IV
Regulation Tag	V
Waste Electrical and Electronic Equipment (WEEE) Directive	VI
Compliance Information	VII
1 About IT-E760	1
1.1 Verifying the Shipment	1
1.2 Brief Introduction	2
1.3 Dimensions	3
1.4 Front-Panel Overview	4
1.5 Rear-Panel Overview	5
1.6 Connecting the Power Cord	7
1.7 Connecting Transformer Module	8
2 Specification	11
2.1 Main Specification	11
2.1.1 IT7622+IT-E761A	11
2.1.2 IT7624+IT-E762A	13
2.1.3 IT7626+IT-E763A	15
2.1.4 IT7622*3+IT-E764A	17
2.1.5 IT7625+IT-E765A	19
2.1.6 IT7627+IT-E766A	21
A Appendix	24
A.1 Specifications of Red and Black Test Lines	24
A.2 Fuse Replacement	25

1 About IT-E760

- ◆ [Verifying the Shipment](#)
- ◆ [Brief Introduction](#)
- ◆ [Dimensions](#)
- ◆ [Front-Panel Overview](#)
- ◆ [Rear-Panel Overview](#)
- ◆ [Connecting the Power Cord](#)
- ◆ [Connecting Transformer Module](#)

1.1 Verifying the Shipment

Unpack the box and check the contents before operating the instrument. If wrong items have been delivered, if items are missing, or if there is a defect with the appearance of the items, contact the dealer from which you purchased the instrument immediately.

The package contents include:

Item	Qty.	Model	Remarks
Transformer Module	X1	IT-E760 Series	IT-E760 series include: IT-E761A/IT-E762A/IT-E763A/IT-E764A/IT-E765A/IT-E766A.
Power Cord	X1	-	User may select an appropriate power cord that matches the specifications of power socket used in the area. See the 1.6 Connecting the Power Cord for details.
Connection wires	X5	-	The connection wires used to connect the module and IT7600 power supply include: System Bus connection wires, output terminals connection wires and Sense terminals connection wires. (Only available when you purchase the single-phase boosting module individually.)

Item	Qty.	Model	Remarks
CD	X1	-	It contains the user manual and other user documentations.
Ex-Factory Test Report	X1	-	It is the test report of the instrument before delivery.

Note

Upon verification of the shipment, keep the package and relevant contents thereof in a safe place. When returning the instrument for warranty service or repair, the specified packing requirements shall be met.

1.2 Brief Introduction

IT-E760 series modules are the transformer accessories of IT7600 series high performance programmable AC power supplies. To meet the test requirements of higher voltage, the output voltage of IT7600 power supply can increase from 300 V to 600 V by working with IT-E760A series boosting modules. The wave selection is limited to sine wave when IT7600 power supply operates at boost mode.

The user can purchase the single-phase boosting module individually, including IT-E761A, IT-E762A and IT-E763A, and make the connection. To avoid faulty connection between three-phase boosting modules and IT7600 power supply, the three-phase boosting modules including IT-E764A, IT-E765A and IT-E766A can be provided only with the correspondent models of IT7600 power supply.

Module model	Module height	Applicable model	Parameter	Phase	Height (with bare machines overlapped)	Height (constituting cabinet)
IT-E761A	3U	IT7622	600V / 1.5A / 675VA	1φ	6U	-
IT-E762A	3U	IT7624	600V / 3A / 1350VA		6U	-
IT-E763A	3U	IT7626	600V / 6A / 2700VA		9U	15U
IT-E764A	4U	IT7622*3	600V / 1.5A / 2025VA	3φ	-	15U
IT-E765A	4U	IT7625	600V / 3A / 4050VA		-	15U
IT-E766A	4U	IT7627	600V / 6A / 8100VA		-	27U

1.3 Dimensions

Different models of IT-E760A series boosting modules have different sizes. The detailed dimensions are shown as below.

Model: IT-E761A / IT-E762A / IT-E763A

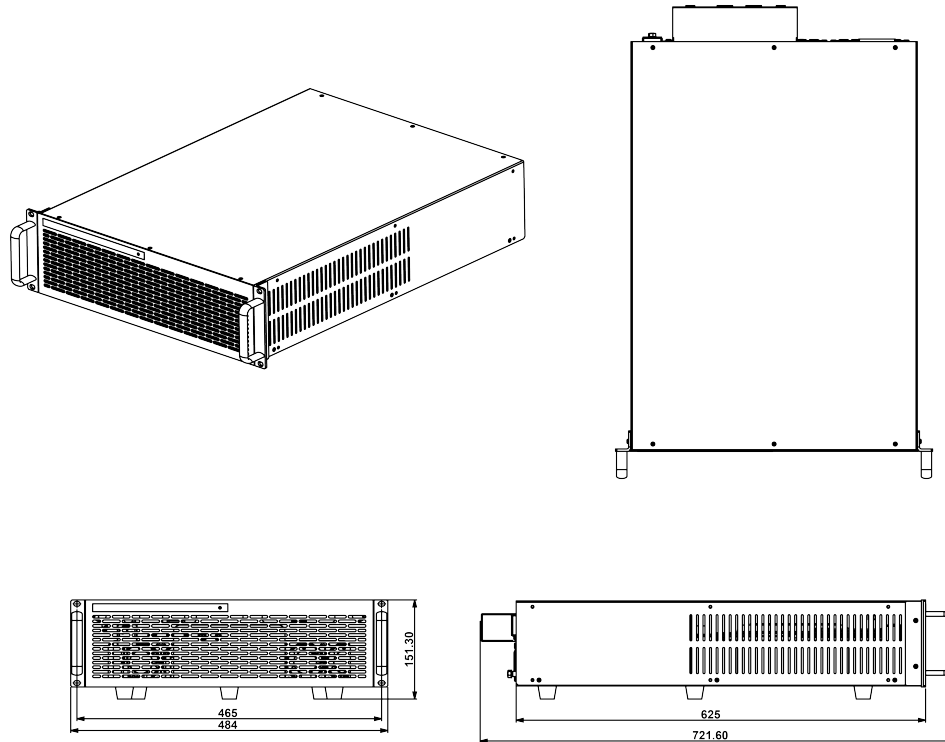

Model: IT-E764A / IT-E765A / IT-E766A

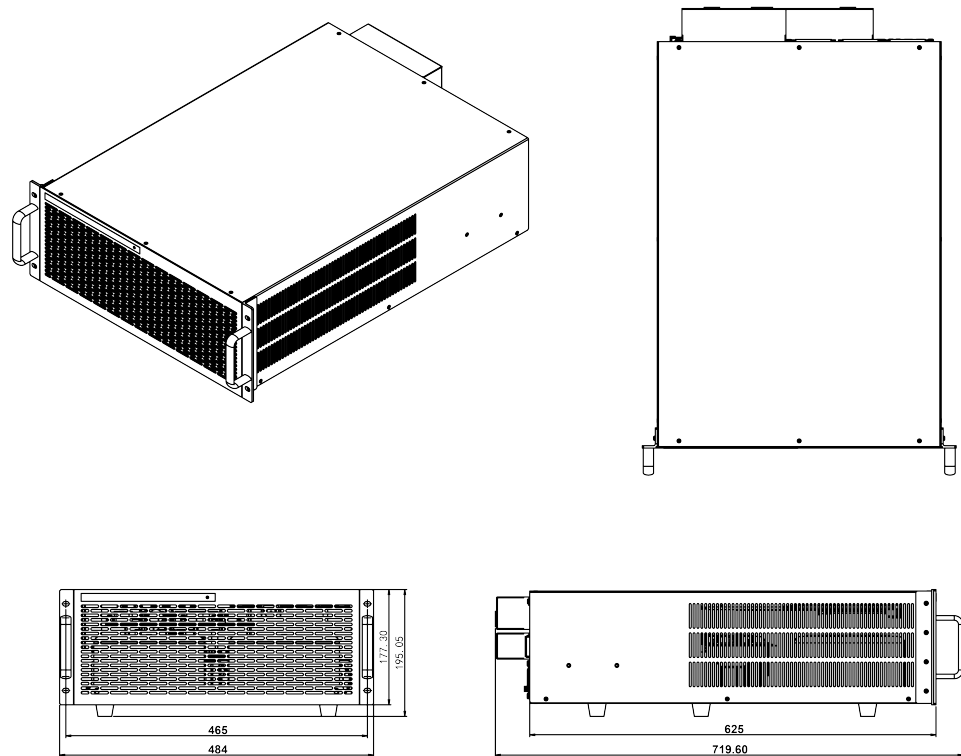

1.4 Front-Panel Overview

All of the IT-E760A series boosting module have the same front panels. The detailed descriptions are shown as below.

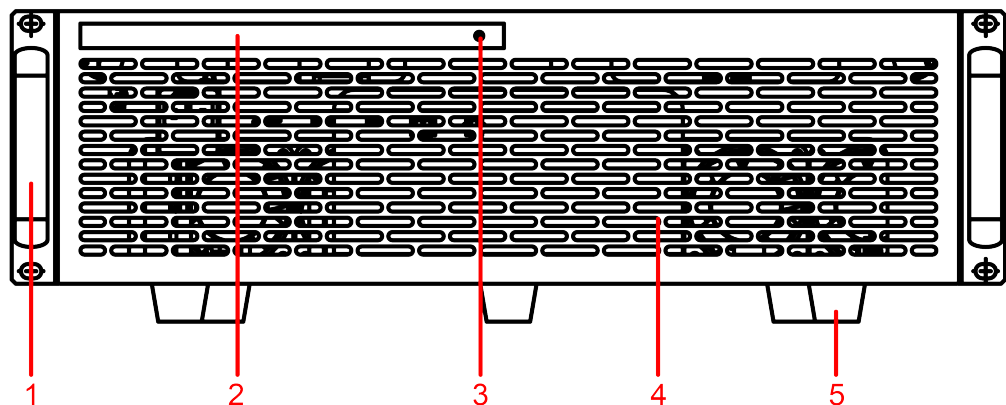

No.	Name	Description
1	Handle	Handle for moving the instrument easily.
2	Nameplate	Displays the product model, parameters and other information.
3	Status Indicator	Displays the present status, including the following three status: <ul style="list-style-type: none"> • When the green light is lit, indicates that the instrument operates normally. • When the red light is lit, indicates that the instrument is in an abnormal status. • When the light is dark, indicates that the instrument is not powered.
4	Inlet holes	Air inlet holes for cooling the instrument.
5	Rubber feet	Rubber feet in five locations can reduce vibration.

1.5 Rear-Panel Overview

Different models of IT-E760A series boosting modules have different rear panels. The detailed descriptions are shown as below.

- Model: IT-E761A / IT-E762A / IT-E763A

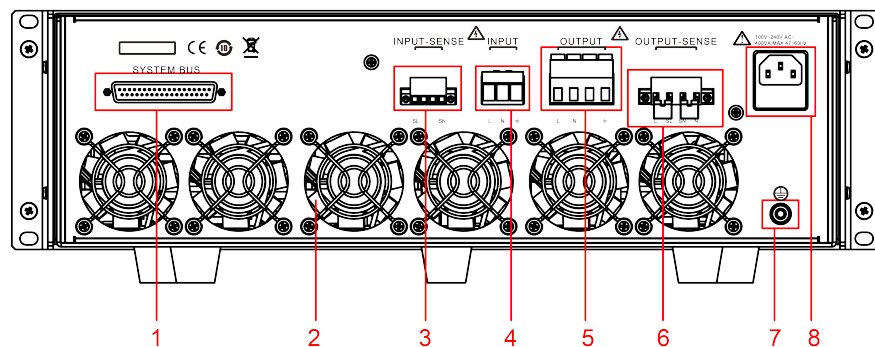

No.	Name	Description
1	System bus interfaces	Used for communication between IT-E760A and IT7600.
2	Fans	Fans for cooling the instrument.

No.	Name	Description
3	Sense input interfaces	Used to connect sense terminals of IT7600 power supply.
4	Input interfaces	Used to connect output terminals of IT7600 power supply.
5	Output interfaces	Used to connect DUT.
6	Sense output interfaces	Connecting the sense output interfaces and the output interface to DUT can maximize measurement accuracy.
7	Ground screw	Ground screw for making chassis ground connections.
8	AC power input socket (including fuse)	Used to connect AC power to start instrument, supports 110 V to 240 V.

- Model: IT-E764A / IT-E765A / IT-E766A

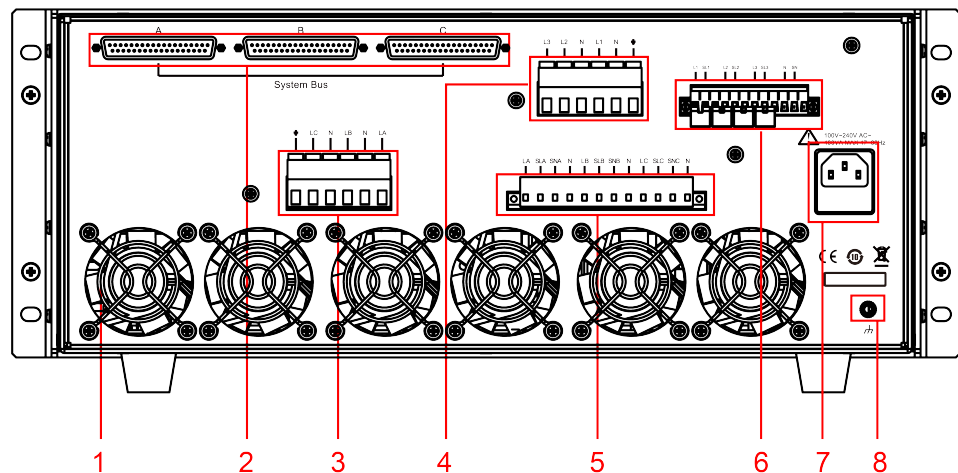

No.	Name	Description
1	Fans	Fans for cooling the instrument.
2	System bus interfaces	Used for communication between IT-E760A and IT7600.
3	Output interfaces	Used to connect DUT.
4	Input interfaces	Used to connect output terminals of IT7600 power supply.
5	Sense output interfaces	Connecting the sense output interfaces and the output interface to DUT can maximize measurement accuracy.
6	Sense input interfaces	Used to connect sense terminals of IT7600 power supply.

No.	Name	Description
7	AC power input socket (including fuse)	Used to connect AC power to start instrument, supports 110 V to 240 V.
8	Ground screw	Ground screw for making chassis ground connections.

1.6 Connecting the Power Cord

Precautions

To prevent electric shock and damage to the instrument, observe the following precautions.

WARNING

- The power cords supplied with this product is certified for safety. In case the supplied lines assembly needs to be replaced, or an extension lines must be added, be sure that it can meet the required power ratings of this product. Any misuse voids the warranty of this product.
- Before connecting power cord, be sure to confirm that the power voltage matches with the supply voltage.
- Verify that there is no dangerous voltage on the terminals before connecting the power cord.
- To avoid fire or electric shock, make sure to use the power cord supplied by ITECH.
- Do not use an extended power cord without protective grounding, otherwise the protection function will fail.
- Be sure to connect the main power socket to the power outlet with protective grounding. Do not use terminal board without protective grounding.
- The instrument rear panel provides a separate screw used for chassis ground. Please make proper connections. In the event of a failure, not using a properly grounded protective earth and grounded outlet may result in personal injury or death due to electric shock.

Categories of Power Cords

Please select appropriate power cords appropriate to local voltage based on the specifications of power cords below. If purchased model fails to meet local voltage requirements, please contact distributor or factory for change.

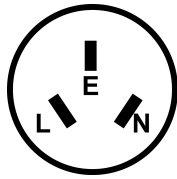

China
IT-E171

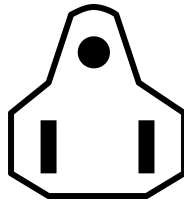

United States &
Canada & Japan
IT-E172

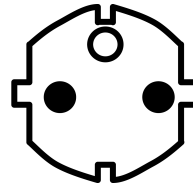

Europe
IT-E173

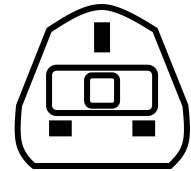

England
IT-E174

AC Power Input Level

IT-E760 transformer modules operate at 100 V to 240 V with a frequency of 47 Hz or 63 Hz.

Connecting the Power Cord

To connect the power cord:

1. Connect the female end of the supplied line cord to the AC receptacle on the rear panel.
2. Connect the plug of the power cord to a grounded AC outlet.
3. Make proper connections of the chassis ground.

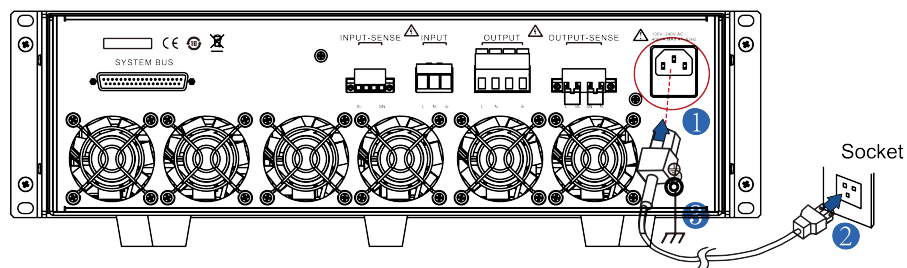

1.7 Connecting Transformer Module

The transformer function can be realized by properly connecting the IT-E760 series module and turning on the transformer accessory function of the IT7600 power supply.

Connection Method

Take IT-E761A as an example, the connection diagram and description are as follows.

IT-E761A

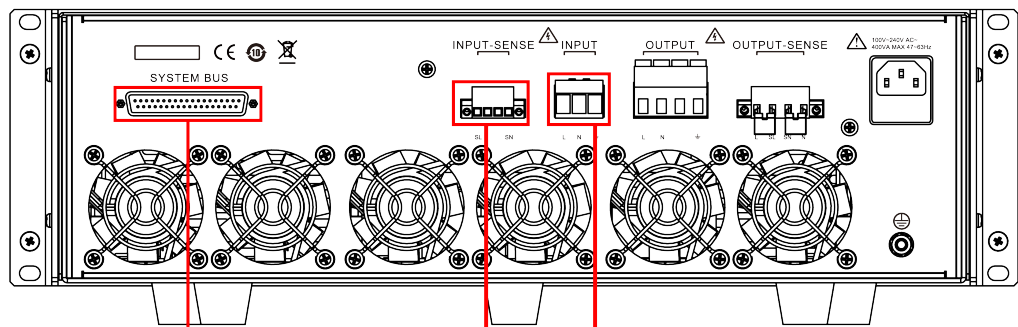

IT7622

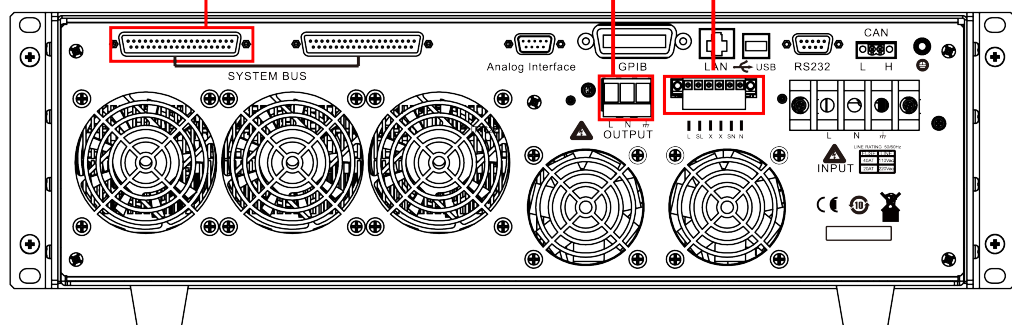

The connection description are as follows.

1. Connect the system bus interfaces between IT-E761A boosting module and IT7622 power supply.
2. Connect the output terminals of IT7622 power supply to the input terminals of IT-E761A boosting module.
 - a. Remove the terminal cover.
 - b. Connect the L, N and ground terminals to the corresponding terminals. Before inserting, please loose the screw, lock the screw when it is inserted.
3. Connect the sense terminals of IT7622 power supply to the INPUT-SENSE terminals of IT-E761A boosting module.
 - a. Disconnect the wires/short clips between L and SL, N and SN of IT7622 power supply.
 - b. Connect the SL and SN terminals to the corresponding terminals.

Turning on Transformer Accessory Function

After correctly connecting the module to IT7600 power supply and connecting DUT to the module, the user must turn on the transformer accessory function of IT7600 power supply and configure successfully to achieve the module's transformer effect.

Note

The connection method between the module and DUT is the same as the method of connecting DUT to the IT7600 power supply. Please refer to IT7600 user manual for more details.

The procedures to enable the transformer accessory function on IT7600 power supply are as follows.

1. Press **[Shift] + [Setup]** (Menu) enter into the menu interface.
2. Press **[Next]** to turn the page of the system menu.
3. Select **[Transformer Configure]** and enter into the transformer interface, shown as follow.



Transformer Setup		Disable
Transformer Machine:	IT-E761A	Enable
Transformer Software:	1.00	
Transformer Sn:	012345678901234567	
Transformer V-Abudhabi:	2.056 : 1.000	
Transformer C-Abudhabi:	0.420 : 1.000	
Transformer State:	step-up,Normal,temperature Ok:13,0,0.	
Transformer Funtion	Enable	
Transformer Fan	Auto pwm: 100	
Communication Configure	Transformer Configure	Device Self-Test
		Previous

4. Press **[Enable]** to turn the transformer function on
5. Set the transformer fan speed according to requirement.

2 Specification

This chapter will introduce the main parameters of IT-E760 series transformer modules.

◆ [Main Specification](#)

2.1 Main Specification

2.1.1 IT7622+IT-E761A

Parameter	IT-E761A V2.1
IT-E761A AC Input	
Voltage	100-240Vac
Phase	1φ
Frequency	47-63Hz
IT7622 AC Input	
Voltage	220Vac±10% or 110Vac±10%
Phase	1φ
Frequency	47-63Hz
Max.Current	20A/40A
Power Factor	0.7 (Typical)
IT-E761A AC Output*1	
Max. output power	675VA
Voltage range	4V-600V
Voltage resolution	0.1V
Voltage accuracy	$\pm 0.4\% + (0.4\% + 0.4\% \times K_{\text{freq}}) \times \text{FS} \times 2$ (50HZ-200HZ)
	$\pm 0.4\% + (1\% + 3\% \times K_{\text{freq}}) \times \text{FS} \times 2$ (201HZ-500HZ)
Temp. coefficient	$\pm (0.04\% \text{ per degree from } 25^{\circ}\text{C})$
Max Current(rms)	0-1.5Arms
Max Current(peak)(47-63Hz)	0-4.5Apeak

Parameter		IT-E761A V2.1
Total Harmonic Distortion *3		≤0.5% at 45-500Hz (Resistive Load)
Crest Factor (47-63Hz)		3(Typical)
Line Regulation		≤0.1%FS(Resistive Load)
Load Regulation		≤0.5%FS(Resistive Load)
Dynamic Response Time		≤100us(Typical)
Output Phase		1φ
Meter		
AC voltage	Range	0-600Vac
	Resolution	0.1V
	Accuracy	±0.4%+(0.4%+0.4%×Kfreq)×FS *2 (50HZ-200HZ)
		±0.4%+(1%+3%×Kfreq)×FS *2 (201HZ-500HZ)
Temp. coefficient	±(0.04% per degree from 25°C)	
AC current (rms)	Range	0-1.5Arms
	Resolution	10mA
	Accuracy	±0.5%+(0.8%+0.3%×Kfreq)×FS *2
	Temp. coefficient	±(0.04% per degree from 25°C)
AC current (peak)	Range	0-4.5Apeak
	Resolution	10mA
	Accuracy	±0.5%+(0.8%+0.3%×Kfreq)×FS *2
	Temp. coefficient	±(0.04% per degree from 25°C)
Power	Resolution	10mW
	Accuracy	±0.5%+(0.8%+0.3%×Kfreq)×FS *2
	Temp. coefficient	±(0.04% per degree from 25°C)
Phase Angle	Range	0-360°
	Resolution	1°
	Accuracy	±1°(47-65Hz)
Frequency	Range	47Hz-500Hz
	Resolution	0.1Hz
	Accuracy	±0.1%+0.1Hz *3
Other		

Parameter	IT-E761A V2.1
Protection	OPP、OCP、OTP
Interface	GPIB、USB、LAN、RS232、CAN
Storage	10 groups
Dimension	6U
Weight	75KG

*1: The precondition for the output is working with IT7622.

*2: FS= Full Scale; Vrms=600 Vac; Irms=1.5 A; Ipk=4.5 A; P=675 VA;

*3: The lowest voltage for the test frequency accuracy is 60 Vac.

2.1.2 IT7624+IT-E762A

Parameter	IT7624+IT-E762A V2.1
IT-E762A AC Input	
Voltage	100-240Vac
Phase	1φ
Frequency	47-63Hz
IT7624 AC Input	
Voltage	220Vac±10% or 110Vac±10%
Phase	1φ
Frequency	47-63Hz
Max.Current	30A/60A
Power Factor	0.7 (Typical)
IT-E762A AC Output*1	
Max. output power	1.35KVA
Voltage range	4V-600V
Voltage resolution	0.1V
Voltage accuracy	$\pm 0.4\% + (0.4\% + 0.4\% \times K_{\text{freq}}) \times \text{FS} \times 2$ (50HZ-200HZ)
	$\pm 0.4\% + (1\% + 3\% \times K_{\text{freq}}) \times \text{FS} \times 2$ (201HZ-500HZ)
Temp. coefficient	$\pm (0.04\% \text{ per degree from } 25^{\circ}\text{C})$
Max Current(rms)	0-3Arms
Max Current(peak)(47-63Hz)	0-9Apeak

Parameter		IT7624+IT-E762A V2.1
Total Harmonic Distortion *3		≤0.5% at 45-500Hz (Resistive Load)
Crest Factor (47-63Hz)		3 (Typical)
Line Regulation		≤0.1%FS(Resistive Load)
Load Regulation		≤0.5%FS(Resistive Load)
Dynamic Response Time		≤100us (Typical)
Output Phase		1φ
Meter		
AC voltage	Range	0-600Vac
	Resolution	0.1V
	Accuracy	±0.4%+(0.4%+0.4%×Kfreq)×FS *2 (50HZ-200HZ)
		±0.4%+(1%+3%×Kfreq)×FS *2 (201HZ-500HZ)
Temp. coefficient	±(0.04% per degree from 25°C)	
AC current (rms)	Range	0-3Arms
	Resolution	10mA
	Accuracy	±0.5%+(0.8%+0.3%×Kfreq)×FS *2
	Temp. coefficient	±(0.04% per degree from 25°C)
AC current (peak)	Range	0-9Apeak
	Resolution	10mA
	Accuracy	±0.5%+(0.8%+0.3%×Kfreq)×FS *2
	Temp. coefficient	±(0.04% per degree from 25°C)
Power	Resolution	10mW
	Accuracy	±0.5%+(0.8%+0.3%×Kfreq)×FS *2
	Temp. coefficient	±(0.04% per degree from 25°C)
Phase Angle	Range	0-360°
	Resolution	1°
	Accuracy	±1°(47-65Hz)
Frequency	Range	47Hz-500Hz
	Resolution	0.1Hz
	Accuracy	±0.1%+0.1Hz *3
Other		

Parameter	IT7624+IT-E762A V2.1
Protection	OPP、OCP、OTP
Interface	GPIB、USB、LAN、RS232、CAN
Storage	10 groups
Dimension	6U
Weight	80KG

*1: The precondition for the output is working with IT7624.

*2: FS= Full Scale; Vrms 600 Vac; Irms=3 A; Ipk=9 A; P=1350 VA.

*3: The lowest voltage for the test frequency accuracy is 60 Vac.

2.1.3 IT7626+IT-E763A

Parameter	IT7626+IT-E763A V2.1
IT-E763A AC Input	
Voltage	100-240Vac
Phase	1φ
Frequency	47-63Hz
IT7626 AC Input	
Voltage	220Vac±10%
Voltage	1φ
Frequency	47-63Hz
Max.Current	60A
Power Factor	0.7 (Typical)
IT-E763A AC Output*1	
Max. output power	2.7 KVA
Voltage range	4V-600V
Voltage resolution	0.1V
Voltage accuracy	$\pm 0.4\% + (0.4\% + 0.4\% \times K_{\text{freq}}) \times \text{FS} \times 2$ (50HZ-200HZ)
	$\pm 0.4\% + (1\% + 3\% \times K_{\text{freq}}) \times \text{FS} \times 2$ (201HZ-500HZ)
Temp. coefficient	$\pm(0.04\%$ per degree from 25°C)
Max Current(rms)	0-6 Arms
Max Current(peak)(47-63Hz)	0-18 Apeak

Parameter		IT7626+IT-E763A V2.1
Total Harmonic Distortion *3		≤0.5% at 45-500Hz (Resistive Load)
Crest Factor(47-63Hz)		3 (Typical)
Line Regulation		≤0.1%FS(Resistive Load)
Load Regulation		≤0.5%FS(Resistive Load)
Dynamic Response Time		≤100us (Typical)
Output Phase		1φ
Meter		
AC voltage	Range	0-600Vac
	Resolution	0.1V
	Accuracy	±0.4%+(0.4%+0.4%×Kfreq)×FS *2 (50HZ-200HZ)
		±0.4%+(1%+3%×Kfreq)×FS *2 (201HZ-500HZ)
Temp. coefficient	±(0.04% per degree from 25°C)	
AC current (rms)	Range	0-6 Arms
	Resolution	10mA
	Accuracy	±0.5%+(0.8%+0.3%×Kfreq)×FS *2
	Temp. coefficient	±(0.04% per degree from 25°C)
AC current (peak)	Range	0-18 Apeak
	Resolution	10mA
	Accuracy	±0.5%+(0.8%+0.3%×Kfreq)×FS *2
	Temp. coefficient	±(0.04% per degree from 25°C)
Power	Resolution	10mW
	Accuracy	±0.5%+(0.8%+0.3%×Kfreq)×FS *2
	Temp. coefficient	±(0.04% per degree from 25°C)
Phase Angle	Range	0-360°
	Resolution	1°
	Accuracy	±1°(47-65Hz)
Frequency	Range	47Hz-500Hz
	Resolution	0.1Hz
	Accuracy	±0.1%+0.1Hz *3
Other		

Parameter	IT7626+IT-E763A V2.1
Protection	OPP、OCP、OTP
Interface	GPIB、USB、LAN、RS232、CAN
Storage	10 groups
Dimension	15U
Weight	183KG

*1: The precondition for the output is working with IT7626.

*2: FS= Full Scale; Vrms=600 Vac; Irms=6 A; Ipk=18 A; P=2700 VA.

*3: The lowest voltage for the test frequency accuracy is 60 Vac.

2.1.4 IT7622*3+IT-E764A

Parameter	IT7622*3+IT-E764A V1.1
IT-E764A AC Input	
Voltage	100-240Vac
Phase	1φ
Frequency	47-63Hz
IT7622*3 AC Input	
Voltage	380Vac±10%(Y)
Phase	3φ
Frequency	47-63Hz
Max.Current	20A
Power Factor	0.7 (Typical)
IT-E764A AC Output*1	
Output Phase	3φ
Max. output power for each phase	675VA
Voltage range	4V-600V
Voltage resolution	0.1V
Voltage accuracy	$\pm 0.4\% + (0.4\% + 0.4\% \times K_{\text{freq}}) \times \text{FS} \times 2$ (50HZ-200HZ)
	$\pm 0.4\% + (1\% + 3\% \times K_{\text{freq}}) \times \text{FS} \times 2$ (201HZ-500HZ)
Temp. coefficient	$\pm(0.04\%$ per degree from 25°C)
Current(rms) for each phase	0-1.5 Arms

Parameter		IT7622*3+IT-E764A V1.1
Current (peak) for each phase (47-63Hz)		0-4.5 Apeak
Total Harmonic Distortion *3		≤0.5% at 45-500Hz (Resistive Load)
Crest Factor (47-63Hz)		3 (Typical)
Line Regulation		≤0.1%FS(Resistive Load)
Load Regulation		≤0.5%FS(Resistive Load)
Dynamic Response Time		≤100us (Typical)
Output Phase		3φ
Meter		
AC voltage	Range	0-600Vac
	Resolution	0.1V
	Accuracy	±0.4%+(0.4%+0.4%×Kfreq)×FS *2 (50HZ-200HZ)
		±0.4%+(1%+3%×Kfreq)×FS *2 (201HZ-500HZ)
Temp. coefficient	±(0.04% per degree from 25°C)	
AC current (rms)	Range	0-1.5 Arms
	Resolution	10mA
	Accuracy	±0.5%+(0.8%+0.3%×Kfreq)×FS *2
	Temp. coefficient	±(0.04% per degree from 25°C)
AC current (peak)	Range	0-4.5 Apeak
	Resolution	10mA
	Accuracy	±0.5%+(0.8%+0.3%×Kfreq)×FS *2
	Temp. coefficient	±(0.04% per degree from 25°C)
Power	Resolution	10mW
	Accuracy	±0.5%+(0.8%+0.3%×Kfreq)×FS *2
	Temp. coefficient	±(0.04% per degree from 25°C)
Phase Angle	Range	0-360°
	Resolution	1°
	Accuracy	±1°(47-65Hz)
Frequency	Range	47Hz-500Hz
	Resolution	0.1Hz

Parameter	IT7622*3+IT-E764A V1.1
Accuracy	$\pm 0.1\% + 0.1\text{Hz} \times 3$
Other	
Protection	OPP、OCP、OTP
Interface	GPIB、USB、LAN、RS232、CAN
Storage	10 groups
Dimension	15U
Weight	236KG

*1: The precondition for the output is working with IT7622*3. The specifications are for one phase and three phases are the same.

*2: FS= Full Scale; $V_{rms}=600\text{ Vac}$; $I_{rms}=1.5\text{ A}$; $I_{pk}=4.5\text{ A}$; $P=675\text{ VA}$.

*3: The lowest voltage for the test frequency accuracy is 60 Vac.

2.1.5 IT7625+IT-E765A

Parameter	IT7625+IT-E765A V1.1
IT-E765A AC Input	
Voltage	100-240Vac
Phase	1 ϕ
Frequency	47-63Hz
IT7625 AC Input	
Voltage	380Vac $\pm 10\%$ (Y)
Phase	3 ϕ
Frequency	47-63Hz
Max.Current	30A
Power Factor	0.7 (Typical)
IT-E765A AC Output*1	
Output Phase	3 ϕ
Max. output power for each phase	1.35KVA
Voltage range	4V-600V
Voltage resolution	0.1V
Voltage accuracy	$\pm 0.4\% + (0.4\% + 0.4\% \times K_{freq}) \times FS \times 2$ (50HZ-200HZ)

Parameter		IT7625+IT-E765A V1.1
		$\pm 0.4\% + (1\% + 3\% \times K_{\text{freq}}) \times \text{FS} \times 2$ (201HZ-500HZ)
Temp. coefficient		$\pm(0.04\%$ per degree from 25°C)
Current(rms) for each phase		0-3 Arms
Current (peak) for each phase (47-63Hz)		0-9 Apeak
Total Harmonic Distortion *3		$\leq 0.5\%$ at 45-500Hz (Resistive Load)
Crest Factor (47-63Hz)		3 (Typical)
Line Regulation		$\leq 0.1\%$ FS(Resistive Load)
Load Regulation		$\leq 0.5\%$ FS(Resistive Load)
Dynamic Response Time		$\leq 100\mu\text{s}$ (Typical)
Output Phase		3 ϕ
Meter		
AC voltage	Range	0-600Vac
	Resolution	0.1V
	Accuracy	$\pm 0.4\% + (0.4\% + 0.4\% \times K_{\text{freq}}) \times \text{FS} \times 2$ (50HZ-200HZ)
		$\pm 0.4\% + (1\% + 3\% \times K_{\text{freq}}) \times \text{FS} \times 2$ (201HZ-500HZ)
Temp. coefficient	$\pm(0.04\%$ per degree from 25°C)	
AC current (rms)	Range	0-3 Arms
	Resolution	10mA
	Accuracy	$\pm 0.5\% + (0.8\% + 0.3\% \times K_{\text{freq}}) \times \text{FS} \times 2$
	Temp. coefficient	$\pm(0.04\%$ per degree from 25°C)
AC current (peak)	Range	0-9 Apeak
	Resolution	10mA
	Accuracy	$\pm 0.5\% + (0.8\% + 0.3\% \times K_{\text{freq}}) \times \text{FS} \times 2$
	Temp. coefficient	$\pm(0.04\%$ per degree from 25°C)
Power	Resolution	10mW
	Accuracy	$\pm 0.5\% + (0.8\% + 0.3\% \times K_{\text{freq}}) \times \text{FS} \times 2$
	Temp. coefficient	$\pm(0.04\%$ per degree from 25°C)
Phase Angle	Range	0-360°
	Resolution	1°

Parameter		IT7625+IT-E765A V1.1
	Accuracy	$\pm 1^\circ$ (47-65Hz)
Frequency	Range	47Hz-500Hz
	Resolution	0.1Hz
	Accuracy	$\pm 0.1\% + 0.1\text{Hz} \times 3$
Other		
Protection	OPP、OCP、OTP	
Interface	GPIB、USB、LAN、RS232、CAN	
Storage	10 groups	
Dimension	15U	

*1: The precondition for the output is working with IT7625. The specifications are for one phase and three phases are the same.

*2: FS= Full Scale; $V_{rms}=600\text{ Vac}$; $I_{rms}=3\text{ A}$; $I_{pk}=9\text{ A}$; $P=1350\text{ VA}$.

*3: The lowest voltage for the test frequency accuracy is 60 Vac.

2.1.6 IT7627+IT-E766A

Parameter		IT7627+IT-E766A V1.1
IT-E766A AC Input		
Voltage	100-240Vac	
Phase	1 ϕ	
Frequency	47-63Hz	
IT7627 AC Input		
Voltage	380Vac $\pm 10\%$ (Y)	
Phase	3 ϕ	
Frequency	47-63Hz	
Max.Current	60A	
Power Factor	0.7 (Typical)	
IT-E766A AC Output*1		
Output Phase	3 ϕ	
Max. output power for each phase	2.7 KVA	
Voltage range	4V-600V	
Voltage resolution	0.1V	

Parameter		IT7627+IT-E766A V1.1	
Voltage accuracy		$\pm 0.4\% + (0.4\% + 0.4\% \times K_{\text{freq}}) \times \text{FS} \times 2$ (50HZ-200HZ)	
		$\pm 0.4\% + (1\% + 3\% \times K_{\text{freq}}) \times \text{FS} \times 2$ (201HZ-500HZ)	
Temp. coefficient		$\pm(0.04\%$ per degree from 25°C)	
Current(rms) for each phase		0-6 Arms	
Current (peak) for each phase (47-63Hz)		0-18 Apeak	
Total Harmonic Distortion *3		$\leq 0.5\%$ at 45-500Hz (Resistive Load)	
Crest Factor (47-63Hz)		3 (Typical)	
Line Regulation		$\leq 0.1\%$ FS(Resistive Load)	
Load Regulation		$\leq 0.5\%$ FS(Resistive Load)	
Dynamic Response Time		$\leq 100\mu\text{s}$ (Typical)	
Output Phase		3 ϕ	
Meter			
AC voltage	Range	0-600Vac	
	Resolution	0.1V	
	Accuracy		$\pm 0.4\% + (0.4\% + 0.4\% \times K_{\text{freq}}) \times \text{FS} \times 2$ (50HZ-200HZ)
			$\pm 0.4\% + (1\% + 3\% \times K_{\text{freq}}) \times \text{FS} \times 2$ (201HZ-500HZ)
Temp. coefficient		$\pm(0.04\%$ per degree from 25°C)	
AC current (rms)	Range	0-6 Arms	
	Resolution	10mA	
	Accuracy	$\pm 0.5\% + (0.8\% + 0.3\% \times K_{\text{freq}}) \times \text{FS} \times 2$	
	Temp. coefficient		$\pm(0.04\%$ per degree from 25°C)
AC current (peak)	Range	0-18 Apeak	
	Resolution	10mA	
	Accuracy	$\pm 0.5\% + (0.8\% + 0.3\% \times K_{\text{freq}}) \times \text{FS} \times 2$	
	Temp. coefficient		$\pm(0.04\%$ per degree from 25°C)
Power	Resolution	10mW	
	Accuracy	$\pm 0.5\% + (0.8\% + 0.3\% \times K_{\text{freq}}) \times \text{FS} \times 2$	
	Temp. coefficient		$\pm(0.04\%$ per degree from 25°C)

Parameter		IT7627+IT-E766A V1.1
Phase Angle	Range	0-360°
	Resolution	1°
	Accuracy	±1°(47-65Hz)
Frequency	Range	47Hz-500Hz
	Resolution	0.1Hz
	Accuracy	±0.1%+0.1Hz *3
Other		
Protection	OPP、OCP、OTP	
Interface	GPIB、USB、LAN、RS232、CAN	
Storage	10 groups	
Dimension	27U	

*1: The precondition for the output is working with IT7627. The specifications are for one phase and three phases are the same.

*2: FS= Full Scale; Vrms 600=Vac; Irms=6 A; Ipk=18 A; P=2700 VA.

*3: The lowest voltage for the test frequency accuracy is 60 Vac.

A Appendix

- ◆ Specifications of Red and Black Test Lines
- ◆ Fuse Replacement

A.1 Specifications of Red and Black Test Lines

ITECH provides you with optional red and black test lines, which are sold individually and you can select for test. For specifications of ITECH test lines and maximum current values, refer to the table below.

Model	Specification	Cross Section	Length
IT-E301/10A	10A	-	1m
IT-E301/30A	30A	6mm ²	1.2m
IT-E301/30A	30A	6mm ²	2m
IT-E301/60A	60A	20mm ²	1.5m
IT-E301/120A	120A	50mm ²	2m
IT-E301/240A	240A	70mm ²	1m
IT-E301/240A	240A	70mm ²	2m
IT-E301/360A	360A	95mm ²	2m

For maximum current of AWG copper wire, refer to table blow.

AWG	10	12	14	16	18	20	22	24	26	28
The Maximum Current Value(A)	40	25	20	13	10	7	5	3.5	2.5	1.7



Note

AWG (American Wire Gage), it means X wire (marked on the wire). The table above lists current capacity of single wire at working temperature of 30°C. For reference only.

A.2 Fuse Replacement

Different models of our company product are supplied with different fuse assembly. The way to replace the fuse changes accordingly. The common ways are as follows. Please choose the corresponding way of disassembly and replacement based on the fuse assembly of the actual instrument.



Note

If there are no fuse assembly on the instrument rear panel, it means that you can't replace the fuse by yourself. Please contact the ITECH engineer on the condition of the same malfunction.

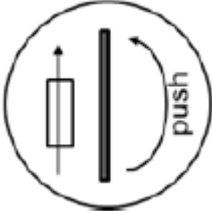
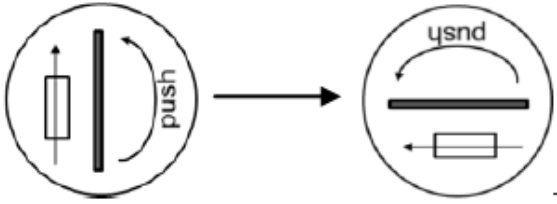
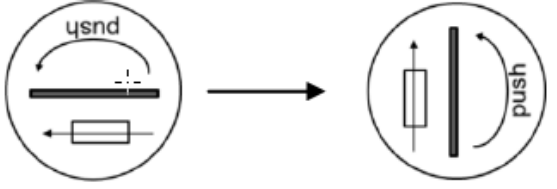
The type of the fuse	The way to replace
	<ol style="list-style-type: none"> 1. Use a screwdriver to push and turn the fuse box anti-clockwise. When turned to 90 degrees, release the screwdriver. Refer to the picture below.  <ol style="list-style-type: none"> 2. The fuse box will bounce up, then you can see the fuse in it. Take out the blown fuse. 3. Please replace with a fuse of the same specification. Refer to the technical specification of the corresponding instrument. 4. When install, put into the fuse box as the picture below. Then use a screwdriver to push and turn the fuse box to 90 degrees clockwise. Refer to the picture below. 



The power cord jack of the instrument includes the fuse. Please refer to the rear panel introduction of the corresponding instrument for the detailed position. The replacement steps for this type of the fuse are as follows.

1. First pull out the power cord, and then take out the fuse block from the power cord jack with a small screwdriver, as shown below.

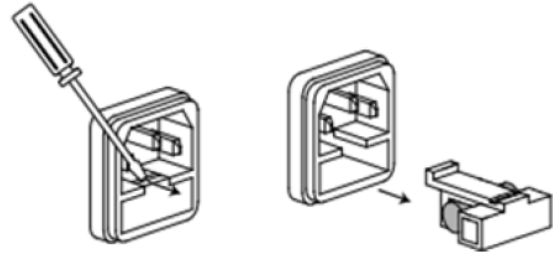

2. Have a visual inspection of the fuse to see whether it is burnt out; if yes, replace it with another fuse of the same specification. Refer to the corresponding technical specifications for fuse rating.
3. After replacement, mount the fuse block to the original position, as illustrated below.

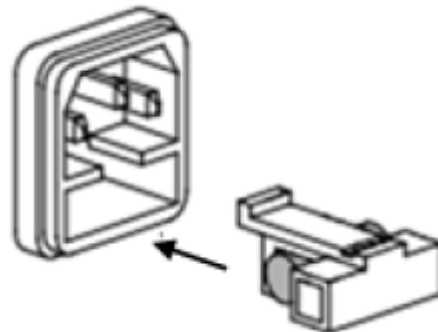

1. Push and turn the fuse box anti-clockwise by hand. When turned to 90 degrees, release the screwdriver.
2. The fuse box will bounce up, then you can see the fuse in it. Take out the blown fuse.
3. Please replace with a fuse of the same specification. Refer to the technical specification of the corresponding instrument.
4. When install, put into the fuse box firstly. Then Push and turn the fuse box to 90 degrees clockwise.

Contact Us

Thanks for purchasing ITECH products. In case of any doubts, please contact us as follows:

1. Refer to accompanying data disk and relevant manual.
2. Visit ITECH website: www.itechate.com.
3. Select the most convenient contact method, for further information.